

LONGWARRY

Food Park



∴ Part of your region ∴

www.longwarry.com

table of contents



Introduction



Origins



Projects



Our Customers



Recognition



Longwarry Plant History



Plant Investments



Vision



Strategy



Financial Information



What We offer



Future Plans

introduction



Corporate Office, Port Melbourne



Ingredients Drying, Dandenong



Fabrication Facility, Dandenong



Milk Powder Plant, Longwarry



origins

Saurin Enterprises was founded in 1993.

Saurin specialises in:

- **Dehydration Technologies:** Only manufacturer of Spray Dryers in Australia
- **Mixing Technologies:** Patented Soliquid –in-line Mixer.
- **Pilot Plants:** Range of Pilot Plants that have been supplied to a large number of universities and Tafe colleges.
- **Process Engineering:** Turnkey plants supplied and commissioned in Australia and Overseas. Recently supplied a 9T/hr Sweetened Condensed Milk Plant to Bangladesh.
- **Special Ingredients Drying:** 200 Kg/hr Spray Dryer built with Saurin technology
- **Research & Development:** Many projects completed with CSIRO, FoodScience, Monash University & University of Western Sydney

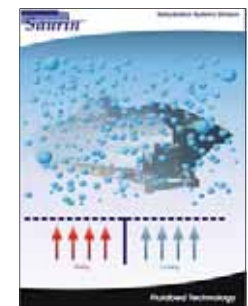
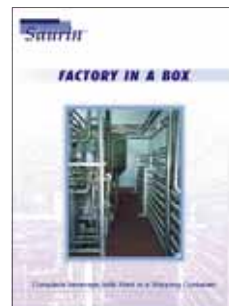

projects

Breast Milk Pasteurisation and Protein Concentration: We have developed these plants for the Breast Milk Foundation. This will save the lives of pre-mature babies and is the first of its kind in the world.

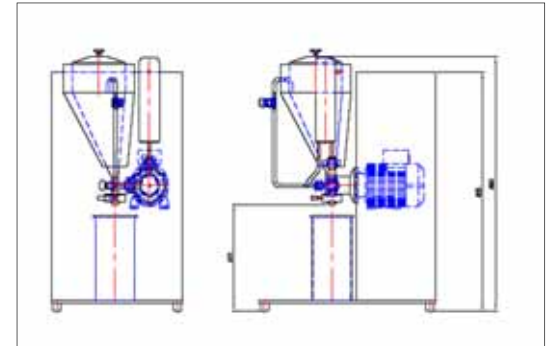

Recovery of Wine from Spent Grape Marc: Marc is a waste product that contaminates our soil. We have developed a process for not only recovering wine but also converting the rest as fertiliser and Grape Seed Oil. This technology was pioneered by Saurin.

Production of Cereals: Breakfast cereals have always been produced on ovens that are expensive and inefficient. We developed a more efficient technology for Sanitarium Australia and Sanitarium New Zealand.



our customers

Vectura Pharmaceuticals, UK

Murray Goulburn

Sanitarium, Australia

SPC-Ardmona

Warrnambool Cheese & Butter

National Foods

Muskvale Flavours

Bonlac Foods

PTI – USA

Danisco, New Zealand

Advanced Nanotechnology

Olive Products, Queensland

University Of Queensland

University of Western Sydney

Sanowara Dairies, Bangladesh

Unilac Sanowara, Bangladesh

Cognis Australia, South Australia

Bega Cheese

Pillsbury Australia

Bead Foods

Poseidon Dips

Melbourne University

Breast Milk Foundation

TAFE Shepparton

Tandou Wines

Sanitarium New Zealand

University of Philippines, Philippines



recognition and media

recognition

City of Melbourne B3000, 2005

Rabobank Agribusiness Innovation, 2003

Cisco System Innovation Award, 2002

Governor of Victoria Export Award, 2002

Institute of Engineers – Innovation Category, 2001

Victorian Small Business Award, 2001

Commonwealth Micro Business Award, 1999

media

Herald Sun

The Australian

Financial Review

ABC Radio / TV

Food & Pack

What's New in Food Technology & Manufacturing

Middle East Food

Ferret.com.au



longwarry plant history

- Origins Longwarry dairy plant dates back to the early 1900's
- 1970's Unigate Australia upgraded the plant and installed the powder manufacture facilities
- 1986 Longwarry Plant becomes part of Drouin Butter Factory.
- 1997 Powder production closed down following the commissioning BFL Darnum Park plant
- 2001 Longwarry plant purchased by the Saurin Group and recommissioned
- 2005 Longwarry begins milk powder production

The plant has been named after the town of Longwarry.
We believe in the future of the community.



plant investments

Significant investment has been made since the purchase of the plant.



3 Tonnes/hr Buttermaker



25 Kg Powder Bagging Line



250,000 Litres Milk Silo



Milk Separation & Standardisation

vision

Our Concept

The opportunity to apply dairy processing innovation and technology expertise to business.

Our Vision

Longwarry Food Park as a modern dairy processing plant utilising world best practice to produce high quality Australian dairy products for retail and food ingredient markets internationally.

Our Mission



To be innovative in our approach to ...

- ... milk procurement
- ... powder manufacturing
- ... cost management
- ... value-added marketing



building a sustainable dairy business which adds value for the benefit of all stakeholders.

strategy

Low capital cost & overheads

- 100% plant equity
- ~ \$2 million invested in plant & efficiency upgrade
- ~ \$1 million further short term expenditure plans

Location advantage

- Single site and infrastructure
- Access to local high quality milk supply
- Low milk collection costs

Sustainable operating basis

- Efficient management structure
- Investment in plant efficiency

Manufacturing process and technology expertise

- Leverage of Saurin Group know-how

Operational flexibility

- Manufacture size targeting niche/value domestic and export markets

Responsible environmental strategy

- All effluent treated on-site



Ian Porter, General Manager (Operations)

financial information

- Strong financial position of Saurin Group
- 100% Longwarry plant equity
- Debt-Free
- Business Plan evaluated and supported by the Banks (Commonwealth Bank, ANZ and Suncorp-Metway)
- Supply chain strategy to achieve efficient movement of seasonal product
- Secured payment terms with customers



what we offer

- A proven track record in Manufacturing Process and Technical Development
- An innovative approach to management with a focus on Efficiency and Quality
- Experienced manufacturing and marketing management
- A sound business strategy with a mix of contract drying and our own powder production
- A competitive milk price
- Operating principles of fairness and integrity in all our dealings
- An active communication programme
- A small company informal and personal approach
- Majority of production will be exported



future plans

- Upgrade the plant capacity from 2.3 Tonnes/hr to 4 Tonnes/hr
- Powder Lecithination Unit
- Specialised powder capability
- Adopt the Best Practice for Energy Efficiency in Spray Drying
- Effluent Treatment System Upgrade
- High Value Dairy Products
- Further development of the Food Park to generate regional employment





Powder Manufacturing Facility

31-41 Mackay St

Longwarry, VIC 3816

Australia

Tel: (+61) 3 5629 9551

Fax: (+61) 3 5629 9553

enquiries@longwarry.com

www.longwarry.com



Corporate Office

6 Westside Avenue,

Port Melbourne, VIC 3207

Australia

Tel: (+61) 3 9646 6771

Fax: (+61) 3 9646 8779

sales@saurin.com.au

www.saurin.com.au